

COOCOM

New ways of using Information Technology for buildings design and management

JÖRGEN MODIN, B.SC., DOCTORATE STUDENT
KBS-Media Lab, Lund University, Box 118, 220 00 Lund, Sweden
<http://delphi.kstr.lth.se>, Jorgen.Modin@kstr.lth.se

*Project SBUF 2087
Lund June 1995*

Abstract. The COOCOM project investigates how information technology in the near and far future can make a better product with its functions and surroundings, and provide good information about the care and use of the product. The product is in this case a building. The acronym COOCOM stands for COOperation and COMMunication. The project particularly focuses on two stages in the life-cycle of a building: Early design and facility management. The COOCOM project is to be regarded as a pre-project that is sweeping over large areas, suggesting future directions of research. In order to make investigations into both the near and far future, the project has covered theoretical *and* practical questions. A number of IT programs and environments were evaluated and three compound electronic documents are designed that show off the possibilities of information technology. CSCW dynamics are investigated with the aid of joint editing tools and graphical representations of discussions. Finally future research directions are proposed.



KBS-Media Lab
Lund University
Box 118
221 00 Lund
Sweden

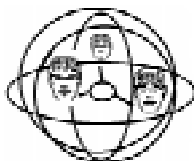

+46-(46)10 73 76/98 43
+46-(46)10 42 12 (fax)
FTP-site: 130.235.88.98
ISDN: +46-(46)37 00 85
WWW: <http://delphi.kstr.lth.se>
Jorgen.Modin@kstr.lth.se

CONTENT

| | | |
|-----------|---|-----------|
| 1. | Project description | 3 |
| 1.1. | The project goals | 3 |
| 1.2. | Participating organizations..... | 4 |
| 2. | Project design..... | 4 |
| 2.1. | Demonstration of Development Progress..... | 5 |
| 2.1. | Reflections on the work group | 6 |
| 3. | Analysis of the problem area..... | 6 |
| 3.1. | Available IT..... | 7 |
| 3.1.1 | Groupware..... | 7 |
| 3.1.2 | Screen sharing | 7 |
| 3.1.3 | Joint editing..... | 8 |
| 3.1.4 | CU-SeeMe..... | 8 |
| 3.1.5 | Virtual reality..... | 8 |
| 3.1.6 | Type of Interaction and trust..... | 9 |
| 3.1.7 | Structured 2 D representations of reasoning..... | 9 |
| 3.2. | Information analysis | 10 |
| 3.2.1 | Interviews..... | 10 |
| 3.2.2 | Graphical top-down Analysis | 11 |
| 3.2.3 | Data-driven analysis..... | 11 |
| 3.2.4 | Rating of data | 12 |
| 4. | Testing new ways of collaborating..... | 12 |
| 3.1. | the course of the simulations..... | 15 |
| 4.1. | The process designs | 16 |
| 4.2.1 | The action-goal system | 18 |
| 4.2.2 | The Structured argumentation system..... | 20 |
| 4.3. | Setting up a permanent collaboration area..... | 20 |
| 4.3.1 | Hermes | 20 |
| 5. | Software design..... | 21 |
| 5.1. | Three types of documents..... | 21 |
| 5.2. | Four types of areas in the documents | 22 |
| 5.3. | The tools used in the documents | 25 |
| 5.4. | File types | 25 |
| 5.5. | User-interface | 25 |
| 6. | Technical aspects..... | 26 |
| 6.1. | Fighting ISA/MS-DOS | 26 |
| 7. | Practical results from the project | 26 |
| 8. | Future projects..... | 26 |
| 8.1. | IT-based Market-driven approach..... | 26 |
| 8.2. | Design of support groups..... | 27 |
| 8.2.1 | Focusing on collaboration over physical distances.... | 27 |
| 9. | References..... | 28 |

1. Project description

1.1. THE PROJECT GOALS

The purpose of the project is to investigate and present how recent developments in information technology, IT, can be used to enhance the cooperation between parties in the building process. We've especially been looking at the communication between designers and the facility manager (COOCOM Etapp I, 1992); how goals can be set and communicated with the aid of Information Technology. The project deals with the technical side of design and facility management, rather than the economical. The project deals rather with the modelling of processes and their support rather than with product modelling.

COOCOM is to fuel a number of spin-off projects, both practical industry-oriented and more theoretical ones. The project therefore includes both research and practical development issues.

On a the practical level it was clear from the outset that:

- *IBM PC* compatibles should be used in the project, because of the prevalence of this standard in Swedish building industry. This would also fit in well with the competence profile of Skanska Software that was to do the bulk of the programming in the project. The use of PCs from the start will make it easier for the industry, it is thought, to make a commercial development based on results of the project. The COOCOM project should also, though, facilitate cross-platform work.
- *ISDN* was to be used for tele communication, to evaluate and draw attention to this digital and commercially available technology.

On a theoretical level we were to test and evaluate a number of new technologies and theories. These include concepts as screen-sharing, joint editing, multimedia, virtual reality, and certain approaches to cognitive interaction with the aid of computers. It also includes overall visions, developed at the KBS-Media Lab (Christiansson, 1992) of how we will live and work in the future.

1.2. PARTICIPATING ORGANIZATIONS

The participating organizations in the COOCOM projects are KBS-Media Lab at the Department of Structural Engineering, Skanska Software, FFNS, LKF and Telia.

Skanska Software is a company in the Skanska building corporation. Skanska Software writes and markets focused applications in the DOS/Windows environments for the building industry. Skanska is a part of Skanska Technology which sells and provides technical competence to the Skanska Building corporation and to other customers.

KBS-Media Lab (Christiansson, 1994) is a research lab at the Department of Structural Engineering at Lund University. KBS-Media Lab specializes into research in the area of Dynamic Knowledge Nets (Christiansson 1992), the representation and communication of knowledge, and CSCW (Computer Supported Collaborative Working).

FFNS is Sweden's largest architect bureau with a steadily growing international commitment in areas as Germany and Malaysia.

LKF is a facility manager that owns and manages several residential areas in Lund.

Telia is the main Swedish tele operator with a heavy interest in new communications solutions.

2. Project design

The research was arranged in three groups, a work group, a steering group and a reference group. The work group does the day-to-day work and generates designs and design ideas for evaluation by the steering group. The steering group sets guidelines for the work group and continuously evaluates the work. The reference group includes representatives of organizations interested in the project.

The Steering group consisted of Nils-Rune Andreasson from Skanska, Per Christiansson (Chairman) from KBS-Media Lab, Bengt Hansson from Construction Management Lund University, Lennart Ingman from the Property Owners Association, Mats Jacobsson/Jack Lindgren from FFNS, Håkan Joelsson from Telia, Börje Svensson from LKF. The work group consisted of Paul Rehn and Jörgen Elvirsson from Skanska, Jörgen Modin (Work group leader) from KBS-Media Lab, Jack Lindgren/Agneta Ljungberg from FFNS and Håkan Ekelund from LKF.

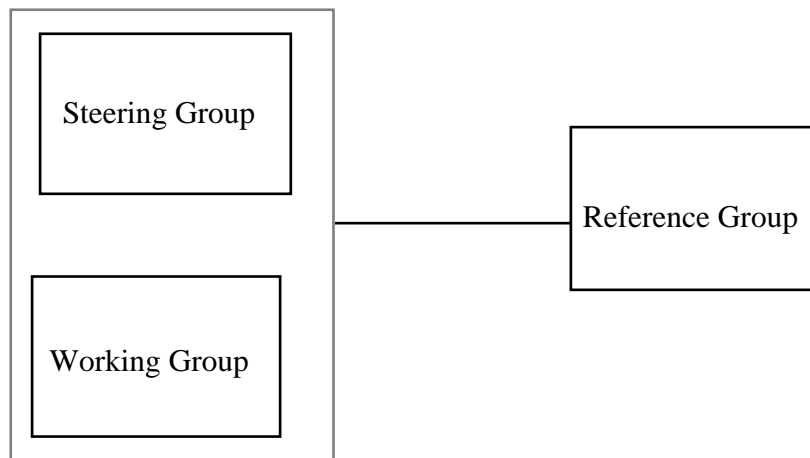

Figure 1 Schema of the relations between the groups

The designs made by the work group are manifested in the form of demonstrators, prototype systems with a growing degree of functionality as the project proceeds.

2.1. DEMONSTRATION OF DEVELOPMENT PROGRESS

The demonstrator method of systems development is a form of prototyping. A rough sketch/prototype of the system is the starting point for communicating opinions and insights on what the final system should look like and how it should behave. This sketch is continually refined until it becomes a valid model of the final system. One could say that the demonstrator starts as an simulation of the final system and ends as the real thing. The software developed in the project started as sketch-like information systems containing design ideas and having limited functionality. The information systems were then continually refined.

The demonstrators developed are used to;

- develop and evaluate interface design
- develop knowledge representations and knowledge handling processes
- make visible technical solutions for communication
- communicate ideas during the development work

Further the demonstrator should have these inherent characteristics;

- it should stimulate persons to look for knowledge within the system
 - it should be open to store non-company information
 - it should stimulate person-to-person cooperation and communication
- (Christiansson & Modin 1993)

2.1. REFLECTIONS ON THE WORK GROUP

Although the development work went smoothly there are a number of experiences to be drawn from the work with regards to the composition of the work group. One is that it is important to gain as much knowledge about the research field as soon as possible and most importantly that this knowledge should be shared by all participants in the work group. Not until this knowledge is spread within the group can the research and development work properly. In order to spread the knowledge within the group a number of artifacts has to be produced: computer programs, protocols from meetings, design proposals, possibly scale models, pictures, diagrams. It takes a lot of time to produce these things. A number of people in the work group must therefore share the work-load of creating them. It's important to have people that are highly creative in the group. The creation of development ideas (as opposed to development critique, which is also an essential part of the development work, but that can be performed chiefly by the steering group) must be done by all key members in the working group. Furthermore the demonstrator development must be in tight collaboration with the specifications development.

3. Analysis of the problem area

A number of areas were to be investigated in the COOCOM project. The project should look into new ways of cooperating with the support of information technology. The communication should be over ISDN. PC compatibles should be used as the main platform. The two latter demands are highly practical. This mix of theoretical and practical issues reflects the different objectives of the stakeholders in the project. How does one go about doing research in such a wide field with both theoretical and practical questions? It's not a bad thing to have such a mix though: To have a theoretical overview to guide the practical work, and to have practical work that puts the theories to test. We went about in the following way:

We made investigations concerning *available information technology* (available software for group interaction and computer systems for facility management). We looked at the forefront of IT building in research and practice. We interviewed our facility manager of perceived *information needs*. We made an analysis of the *information available* for the facility manager in a real-world project. We analyzed the *overall processes* in the work of an architect, a facility manager and a contractor, and we made a schema over the building process to bring the people in the work group on common ground, not least in terminology.

Based on this information and some of the software discovered we designed the demonstrators. We set up two simulations of design meetings with real-world data and tried out advanced IT solutions.

3.1. AVAILABLE IT

We made an investigation into available information technology and available applications relevant to the field. The result is a list of concepts, in the IT field ranging from hardware solutions as different ISDN cards on the market, via computer programs to functions as screen-sharing. Regarding available computer programs the list ranged from extensions to standard software as red-lining software for Auto CAD to entire applications as the UNIX-based Mountain Top facility management system. With the basis of this list software and hardware was selected for initial tests.

3.1.1 Groupware

Groupware systems took a lot of our attention. Groupware is any kind of software that allows and facilitates group work. This includes software for communicating in real-time over a distance, to form a virtual group. This could be with e.g. video, voice or screen-sharing. It includes software for having discussions and reaching agreements in a group. An extensive list of groupware projects and applications, both research-oriented and commercial, can be found in (Malm 1994).

A common way of analyzing groupware with the place-time matrix (Olson, 1994). The matrix is shown below with some examples of applications

| Place | Time -> | same time | different time |
|-----------------|---------|--|--------------------------|
| same place | | white boards, structured discussions, joint editing | multimedia kiosks |
| different place | | video conferencing, screen-sharing, joint editing, Internet relay chat | usenet news, lotus notes |

Figure 2 Time-place matrix with examples

3.1.2 Screen sharing

The communication can be in the form of screen-sharing, also called WYSIWIS (What You See Is What I See). Examples are Timbuktu (Mac/Windows) and Carbon copy and co-session (DOS/Windows).

3.1.3 Joint editing

Joint editing means that several people can view and edit the same document at the same time. To allow people to do this, the program restricts access on a sub-document level, e.g. on a character level or paragraph level in a word processor, or on a drawing object level in a drawing program. The restriction to parts of the document can be based on ownership or on who selects a part first. On a serious scale, the access could be mapped on a central database management system.

An joint editing application that has sprung out of research is the ShrEdit application (Baecker et.al, 1993), (Olson et.al. , 1993). It also monitors how a user works, for research purposes..

A commercial application for joint editing is the Aspects program [Group Technologies, Arlington] (Aspects, 1990). Aspects permits simultaneous editing of drawings, word processor documents and bitmaps. In the COOCOM simulation Aspects was used by five users doing simultaneous editing of drawings and text

3.1.4 CU-SeeMe

CU-SeeMe is a video conferencing systems for the Macintosh, developed at Cornell University. It uses the TCP/IP protocol and can therefore be used on the vast Internet (Quarterman, 1990). The software is free and requires a Macintosh with a VideoSpigot frame grabber or a Macintosh AV. You also need a video camera and microphone. Theoretically one can sustain real-time video conferencing with anybody in the world connected to the Internet. In reality the bandwidth must allow reasonable frame rate and picture quality. Tests with an University in Virginia shows it is indeed possible to communicate world-wide on the Internet albeit with low frame-rates. With a piece of UNIX software, a "reflector", CU-SeeMe allows multi-casting, where several can participate in a conference. The system can of course also be used on a TCP/IP capable network separated or filtered from the traffic on internet. A SUN video conferencing system can use the CU-SeeMe protocol.

3.1.5 Virtual reality

The KBS-Media Lab favors communications solutions where people sit together, communicating with other groups.

The Cave is an interesting experimental system at the University of Illinois at Chicago. All sides and the ceiling in a room are covered with computer graphics projections. This allows for a virtual reality experience akin to a projection helmet system but with a very important improvement: It doesn't require physical isolation. With the CAVE you can work in a physical

group that you can see and touch in actual reality and explore the information space together .

3.1.6 *Type of Interaction and trust*

A matrix that well covers the needs of the COOCOM project is suggested below.

| | | | |
|----------------------|------|---|--------------------|
| | | <i>Context:</i> | |
| | | Known | Not Knownn |
| <i>Participants:</i> | Few | Collaboration same task(s) towards same or different goals | Negotiation |
| | Many | Coordination/ Cooperationon different (sub)tasks towards the same goal | Market |

Figure 3 Size-Context matrix for classifying groupware systems, suggested by the author.

With this matrix, an example of a Collaboration system is Aspects (Group Technologies Inc.). An example of a Cooperation system is Lotus Notes, Examples of negotiating systems are scarce; some of the systems developed in the COOCOM project fits in. Negotiator Pro (Beacon Expert systems Inc.) is an example of a training system for negotiating. Good examples of market systems are the world-wide stock and currency trading systems.

3.1.7 *Structured 2 D representations of reasoning*

Bernard Bernstein at University of Colorado at Boulder has made a program for creating, editing and analyzing reasoned arguments. It is part of his doctorate thesis. It allows a graphical two-dimensional representation of reasoning with the use of objects and arrows. The objects can be grouped into categories, and so can the relations (arrows) between them. The categories are customizable. MacEuclid has been used for the action-goal and structured argumentation diagrams (Described later in this report) during the simulations. It runs on a standard Mac and we used it with a wall projection monitor.

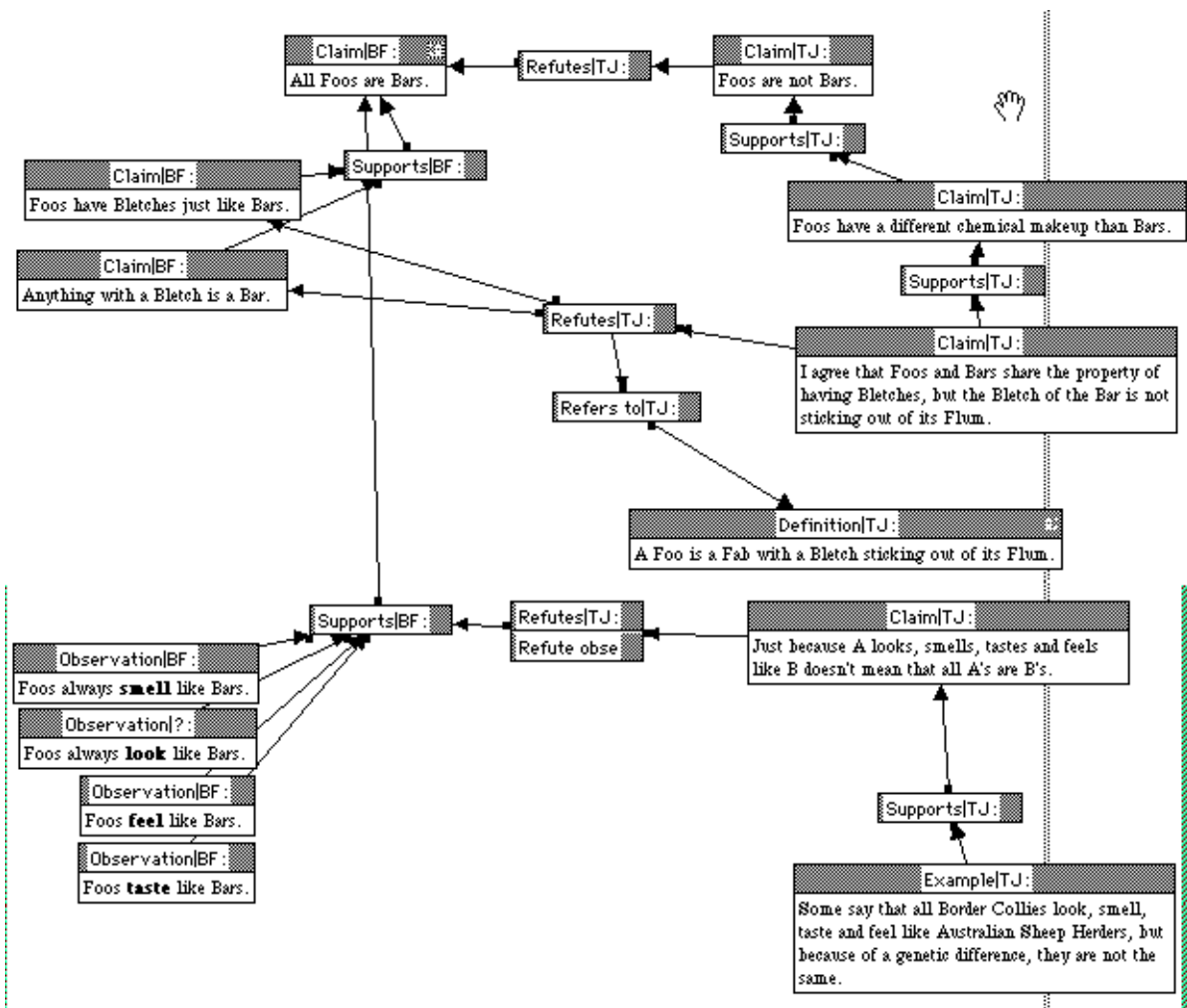

Figure 4 Example of a visualization of reasoning in MacEuclid that came with the program. In short the diagram communicates the nonsense definition that "a foo is a fab with a bletch sticking out of it's flum"

3.2. INFORMATION ANALYSIS

3.2.1 Interviews

Three interviews were performed early on in the project. One with the architect responsible for the design of the Armeria houses, one with the facility manger of the work group and one with an experienced building contractor at Skanska. Questions were asked, among other things, about their work environment from an information perspective (What documents do you

use? What are they used for? How is information conveyed?) and from a process perspective (give names to the main processes of your day-to-day work). Questions were also asked about break points in the building process. Print-outs of the interviews were handed out to the work group. After discussions three dynamic, electronic documents were designed. They became the first specification for the demonstrator development. The three documents are: The *program document*, the *as-built document* and the *facility management document*. These documents formed a starting point for talking about the structure and behavior of appropriate Information Technology. The program document is used for the design phase, and to document the design phase. It helps the designers arrive at a satisfactory solution concerning the building, its environment, its functions and management. It then stores and communicates these designs and the rationales behind them. The as-built document captures information from the construction stage of the building process. It records actual building results and it records deviations from the initial design. The facility management document is a manual for the building. It receives information from the design and building phases from the other documents. The facility management document contains tools tailored to the facility manager's needs. It rates incoming information in importance for the facility management stage, and it integrates other information systems as economy systems.

3.2.2 Graphical top-down Analysis

The phases of design, construction and use of a building were named "produktbestämning" (*product definition, or product design*), "produktframställning" (*product creation*) and "produktanvändning" (*product use*), terms used in the discussions with the Dept. of construction management at LTH. This terminology was unfamiliar to all the participants of the work group, whose views of course are shaped by their respective roles in the building's life-cycle. The "product" terminology was agreed upon, since it shifts the owner of problem (Checkland, 1981), to be the customer. The representatives of FFNS especially welcomed this market-oriented view as belonging to the future. The tradition in Sweden of centralized planning and stringent building regulations is losing ground.

The logical fourth phase, *product disposal and reuse* was not included.

3.2.3 Data-driven analysis

As have been mentioned earlier in this report a real building project was selected from previous collaboration between Skanska and FFNS. The COOCOM project was supplied with the information concerning the Armeria project that was in the possession of FFNS. The information was rated in their importance for the facility management stage by the facility manager of the

work group. This information lay as basis for the design of the as-built demonstrator and the facility management demonstrator.

3.2.4 Rating of data

The information concerning the Armeria project was rated in their importance for the facility management stage by the facility manager of the work group.

4. Testing new ways of collaborating

Not only will the tools we use to perform our work change, also the way we do things will— and should— change. New information technology changes the speed and nature of information flows and hence makes organizations take new shapes. Current work-sharing and procedures used in the building life-cycle will change . How will they change? One way to explore the question is through simulation in a work environment that in some important way differs from the current work environment. The environment may be altered by means of new information technology, a different definition of roles and responsibilities, or by "damaging" the organizational structure ; e.g.: "no you can't do that, you have to do it differently" and in these ways force the organization to self-organize in new patterns.

In December 1993, two simulations were performed at the KBS-Media Lab. The simulations would deal with the design stages of a residential area for retired people, called *Armeria*. The Armeria area had already been built and real material was used in the simulations. In order to stimulate new ways of working, new information technology was introduced and a few people acted as facilitators, in addition to the traditional roles present.

- Communication systems had been set up and technology had been gathered to visualize buildings designs.
- Groupware for same time-same place collaboration had been set up and a number of process designs regarding visualization of discussions had been worked out., see figure 5 below

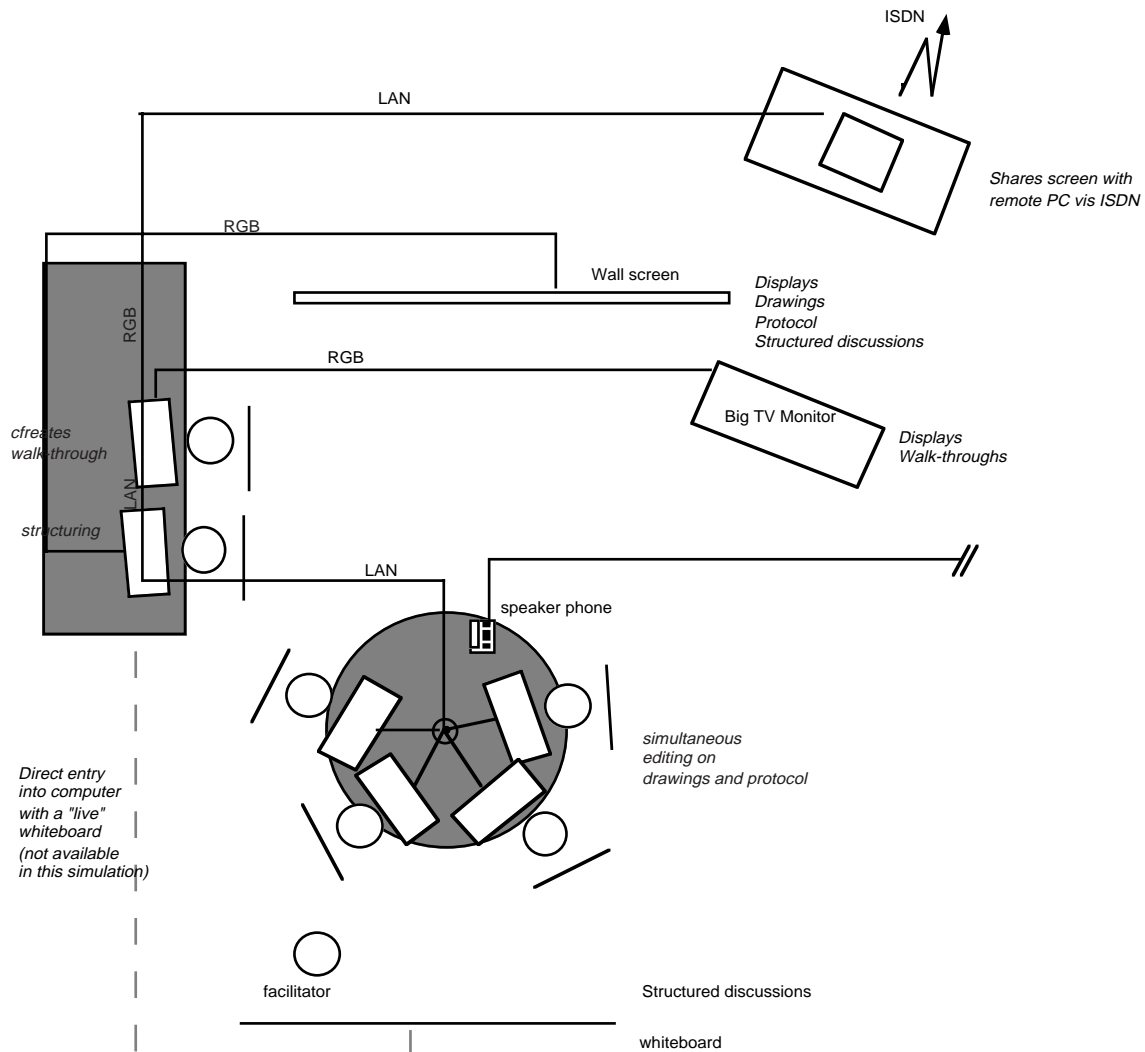

Figure 5 Schema of the set-up for the simulations

A number of people were invited to simulate two design meetings. They were a civil engineer, a facility manager, a representative for the Swedish landlord's association, an architect and a person acting as a representative for the retired people who would inhabit the Armeria houses. The tables below give an overview:

| Real life | Acted as: |
|------------------------------------|-------------------------|
| Civil Engineer | Project leader |
| Facility Manager | himself |
| Architect | himself |
| Rep. for Swedish Landlords' Assoc. | landlord |
| Assoc. Prof. | rep. for retired people |

A mix of hardware and software was tried out:

| Hardware | Functions |
|-------------------|---|
| Apple powerbooks | joint editing |
| IBM compatibles | screen sharing, ISDN communication, protocol bridging |
| Diehl ISDN cards | ISDN Communication |
| AV Mac | walk-throughs |
| Projection panel | structured discussion |
| Loudspeaker phone | talking |
| 28" monitor | displaying walk-throughs |

TABLE 2 Hardware functions in simulations

| Software | Functions |
|--------------------|------------------------------------|
| Demonstrators | integrating work environment |
| Aspects | Joint editing of drawings and text |
| Co-session | Screen sharing |
| AutoCAD | Showing drawings |
| SkaCAD | Showing drawings |
| Quicktime | Playing movies of Walk-throughs |
| Euclid | Display arguments, goals and ends |
| Virtus Walkthrough | Walk-throughs |

TABLE 3 Software functions in simulations

In accordance with the size-trust matrix introduced before the following tasks and parts were included:

| Tasks | Parts |
|------------------------|--------------------------------|
| collaborate/coordinate | Explain, Change |
| negotiate | Claim, argue, support, warrant |
| market | Search |

TABLE 4 Tasks and action parts in the simulation process

4.1. THE COURSE OF THE SIMULATIONS

In the role-play we tried new ways of communicating and interacting. As always some parameters must be varied and some must remain fixed. In our simulation the roles were fixed:

- Facility manager
- Owner
- Tenant
- Project leader and construction engineer
- Architect

What could be varied were the process designs, Confronted with the available resources the project group chose (designed) solutions for cooperation. The resources were in brief:

- Networked portables with joint editing in drawing and word-processing tools
- A wall screen
- A big TV monitor
- One specialist who edited walk-throughs displayed on the TV monitor
- One organization psychologist who visualized the development work and the context of decisions taken, on a wall screen
- One person analyzing the argumentation of the discussion and displaying it on-screen

These three last people worked as *facilitators*, not unlike the game leaders of a MUD, Multi-User Dungeon (Rheingold, 1993).

4.2. THE PROCESS DESIGNS

The agenda was written jointly at the beginning of the meeting with four participants working at the same word-processing document simultaneously, with the project leader functioning as the de facto moderator. In the same

way the protocol was written at the end of the meeting and immediately recognized and approved by the group members, and they had their own copy with them on their local hard disks as they left the meeting. Writing the protocol directly, prevents the protocol writer from interpreting the decisions taken on the meeting in his own way.

Changes were made in the drawings that were available for joint editing, a door was redesigned in a few seconds by the architect. Bigger changes were simulated to be performed by a remote support team at the architect bureau, during the meeting and then sent back to the meeting participants' computers.

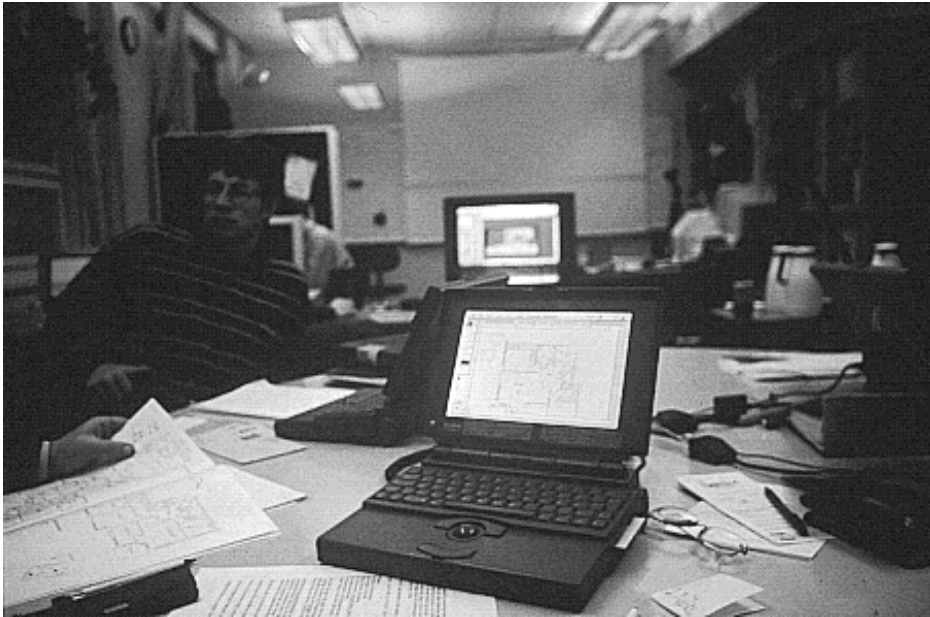

Figure 6 Photo from one of the simulations

Walk-throughs had been created in preparation for the meeting from the architect's 2D drawings. The AutoCAD files had first been converted to .DXF files and then to PICT files and loaded into Virtus Walk-through where they were changed to 3D representations. During the walk-through an awkward placement and combination of kitchen whiteware was spotted and rectified (see figure 7). This placement had not been spotted in the drawings, probably because the whiteware is just visualized with rectangles and letters. The life-like visualizations in the walk-through, especially with the view in virtual eye-height, clearly communicated the design flaw.

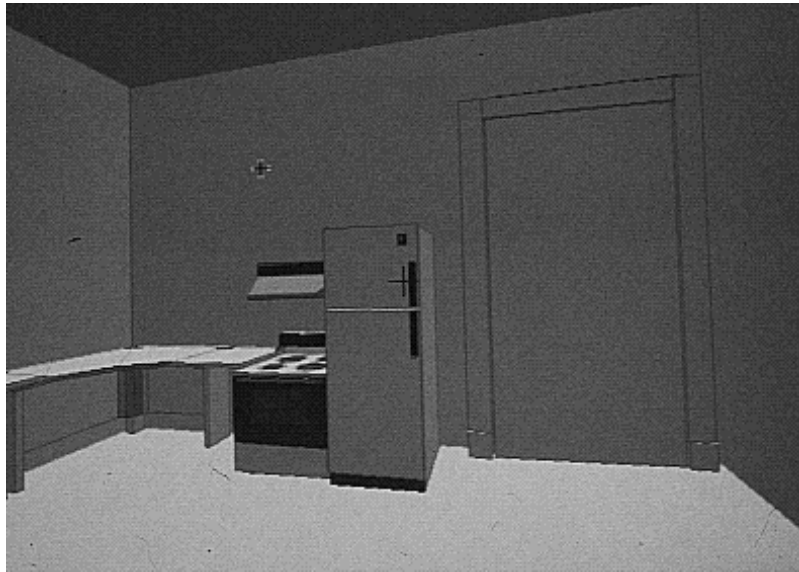

Figure 7 During the walk-through an awkward placement and combination of kitchen whiteware was spotted and rectified

Besides the technical tools there were also three persons available, working as facilitators for the group. The project had so far looked at information that has been assumed to be in traditional form of text, drawings, pictures and photos. But what if the information technology lets us use new ways of representing information? If it does what could they look like. One facilitator ran a walk-through (A technique already in wide-spread use), one analyzed the goals of the participants graphically and one structured the discussions graphically. The two latter let the participants try out structured 2D representations of their discussions. One is chiefly based on the analysis of argumentation in a conflict-oriented situation (Toulmin et al, 1984), the other on reducing prestige and defining possible actions and goals (Eden & Jones, 1984). I will refer to them as the *argumentation* diagrams and the *action-goal* diagrams respectively. These 2D representations may be used for the benefit of the process that creates information (negotiation, discussion) or for the benefit of a later decision point (i.e. documentation).

The argumentation diagrams are used to:

- Communicate standpoints as clearly as possible to the other participants
- Analyze and find weaknesses in a person's line of reasoning.

The action-goal diagrams are used to:

- reduce prestige in a discussion
- define means (What can be done?) during the meeting

- define ends (What is to be achieved?).

4.2.1 *The action-goal system*

Prestige is reduced by exchanging the time-dependent one-dimensional flow of oral speech with a two-dimensional graphical representation. The idea is that it is easier to give up on certain standpoints and reach consensus if you can see and point at parts of the line of reasoning. This method was explained to the working group by Robert Magnusson, who is a doctorate student at the department of applied psychology at Lund University. Robert also assisted at the simulations as one of the facilitators.

The output of the action-goal-diagrams may be used for documentation of decisions taken. The diagrams does not only show what has been decided but also shows the *context* of the decision. In this way, at a decision point for re-building one can see what were the motives for the decisions taken: "They have chosen against forced ventilation because of the noise level, but they didn't mention anything about allergy, just about dust. Hmm, they probably didn't consider that.". Below follows figures 8-9 showing the action-goal diagrams that were produced during the simulations.

There are two types of objects, a concept and its psychological opposite. A psychological opposite in this context means that you're not looking for the logical opposite (which is often just a negation of the defined concept) but something that qualifies the concept by being in conflict with it. This is expressed with the "rather than" relation. The two other relations in the figures are the "positively influences" and "negatively influences" relations. By linking Concept-opposite pairs with other pairs one builds up a network. In an elaborated network with all relations in place, concepts with out-going relations only are possible actions, and concepts with in-going relation only, are goals to be achieved or outcomes to be avoided.

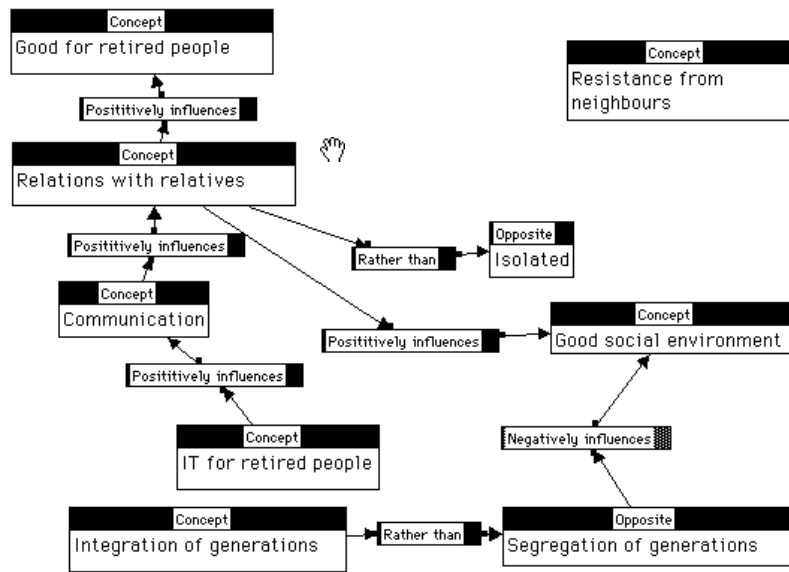

Figure 8 Action-goal diagram from a discussion on the grounds for building apartments for old, from the simulations.

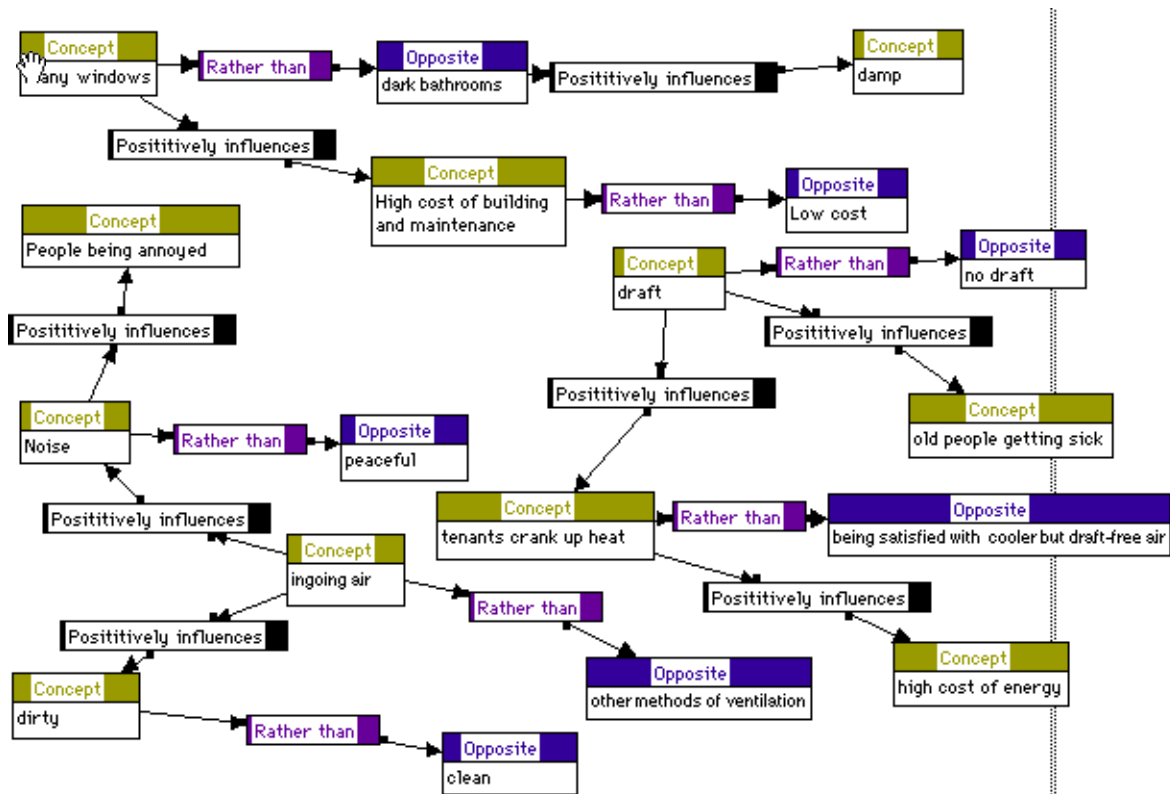

Figure 9 Action-goal diagrams from a discussion concerning choice of ventilation during the simulations.

Nota bene that these diagrams are presented as far as they got during the rather busy simulations. They could be elaborated on much further. The participants in the simulation found the action-goal system interesting and worth investigating further.

4.2.2 The Structured argumentation system

The more conflict-oriented argumentation system was not liked by the participants. No figure of this system has been prepared for this report.

4.3. SETTING UP A PERMANENT COLLABORATION AREA

4.3.1 Hermes

It would be very good to have a permanent electronic collaboration area during the COOCOM projects course. This area could speed up development work and in itself be evaluated for business use. Most participants, if not all, in the building sector in Sweden lack an Internet connection, though this will

change quite rapidly at a to us unknown point in time. To accommodate the present situation we tried out a piece of BBS software that works with a modem over ordinary phone lines. The acronym BBS stands for billboard system. A billboard system in its purest form allows people to post messages, as with an old-fashioned physical billboard, and others can then read the messages. A modern BBS system also contains facilities for electronic mail and for exchanging files. Some BBS systems can communicate with each other and with Internet. FidoNet is a world-wide BBS system based on hierarchically arranged nodes of BBS's communicating over phone lines. The BBS system chosen was Hermes (Price F & Yount Ralph, 1991) , a character-based popular billboard system running on the Mac, but accessible from any computer system with VT100 terminal emulation. Test drives between KBS-media Lab and Skanska Software showed the user interface too difficult to use for business. Currently KBS-Media Lab and Skanska Software are trying out a more modern BBS system called FirstClass in the K3 project. Skanska Software also uses it for customer support. The FirstClass BBS has a very good user interface and is used in Sweden by e.g. all major political parties and a host of companies and other organizations.

5. Software design

5.1. THREE TYPES OF DOCUMENTS

The three hyperdocuments that have been conceived in the COOCOM project can be developed further. The three documents are:

- Program document
- As-built document
- Facility management document.

Three types of hyperdocuments were suggested and then designed and implemented as demonstrators. The first document is the program document. It is used during the design stages as a design and negotiation area. Its task after this stage is to function as a specification for the building, its context and functions. The task of the program document here is to communicate the goals with the building project as clearly as possible, and to reveal the rationales for these goals. Furthermore it shows the resulting design with appropriate displays, e.g. drawings and walk-throughs.

The Program document is a design area that is saved as a specification document. It contains tools for negotiation, design and visualization. The

design decisions and design goals are stored and tagged in the program document as the specification for the project.

The As-built Document is an information capture program that collects and stores information from the building process for later inclusion in the Facility Management document.

The As-built document stores, indexes and categorizes information from building protocols, photographs, complementary drawings, etc. It also draws on information from the program document.

The Facility management document is the user manual for the building. It contains information needed for the facility management (product use) stage. It's job is to present information from the two previous documents in a such a way as to give maximum assistance to the facility manger. Furthermore it should interface other systems, such as economy systems and product databases. The Facility management document should also contain facilities for easy communication with prospective tenants and buyers.

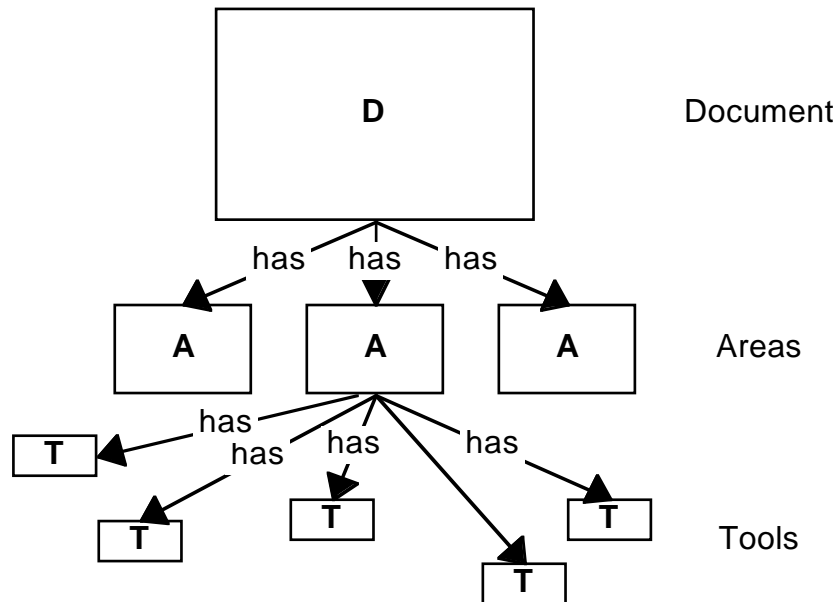

Figure 10 Relation between document, areas and tools.

5.2. FOUR TYPES OF AREAS IN THE DOCUMENTS

Four generic types of areas make up the documents. Each type cater for a different combination of *interaction* and *trust*. These areas are combined to make up each of the suggested hyperdocuments. The four area types are:

- *Collaboration area* — an area for a work situation where the participants are known and their roles are implicitly understood . This could for instance be a collaboration between the architect and different kinds of engineers to create an electronic design of a house with all it's systems. The collaboration area is suited for a day-to day work situation. The collaboration area is used to generate new designs and ideas and for work between trusting partners.
- *Coordination area* — an area for a work situation where the participants are known and their roles are implicitly understood, but where the size of the undertaking makes close collaboration difficult. The Coordination/Cooperation area is used for allocating resources, sharing information and communicating project constraints and design goals. The coordination area is a logical place to continue work that started in the collaboration area.
- *Negotiation area* — an area for negotiating between parties. The parties are known but the context is not. The negotiation area is used for financial negotiation, one-shot deals, and custom agreements.
- *Market area* — an area for a situation with a large number of possible participants and pre-made standardized products and services. The market area contains functions for mass communication, pricing, ordering, electronic shopping and advertising. The market area may be used to exchange *representations of artifacts* .

TABLE 5 Program document

| <u>Area</u> | <u>Tools</u> |
|--------------------------|---|
| Collaboration | -Walk-throughs for designers and constructors -Joint editing tools |
| Coordination/cooperation | PERT, Gantt, Lotus Notes |
| Negotiation | - Action-goal diagrams |
| Market | - Walk-throughs for customers - Fax/send concepts and floor plans |

TABLE 6 As-built document

| <u>Area</u> | <u>Tools</u> |
|--------------------------|---|
| Collaboration | -Joint editing tools -Cube system (Christiansson & Modin 1993) |
| Coordination/cooperation | PERT, Gantt, Lotus Notes |
| Negotiation | -Action-goal diagrams |
| Market | -Building materials databases |

TABLE 7 Facility management document

| <u>Area</u> | <u>Tools</u> |
|--------------------------|---|
| Collaboration | -Walk-throughs for designers and constructors -Joint editing tools |
| Coordination/cooperation | PERT, Gantt, job schedule |
| Negotiation | -Action-goal diagrams |
| Market | -Walk-throughs for customers -Fax floor plans |

5.3. THE TOOLS USED IN THE DOCUMENTS

The tools used in the documents can be of various types, as those described under the heading "Available IT" earlier in the report.

5.4. FILE TYPES

For the implementation phase of the demonstrators we had to settle for a number of file types that could be handled by the demonstrator. We chose MS-WORD, Auto CAD and SkaCAD which turned out to run better in Windows protected mode than Auto Cad

5.5. USER-INTERFACE

In order to perform an action or task in e.g. the Notes system one selects an object and performs an action on an object. With this technique one can create a user-interface with great semantic capability in that if the objects and actions are chosen carefully, one may perform a multitude of tasks by combining them in different ways. This is in line with the object-verb model used in the Macintosh and Windows interfaces and many other GUIs (Graphic User Interface). In the COOCOM project we chose to create a three-fold orthogonality. Firstly there are the *menus* that contain data. Then there are *buttons* that perform actions. Thirdly there is a *palette* that reports on the information status, or context, to the user.

6. Technical aspects

6.1. FIGHTING ISA/MS-DOS

The ISDN cards were used in an IBM 486 PS/VP and a VICTOR 486 PC, both with ISA buses. It took a good week to get the ISDN cards to function properly with the other cards present, the operating system and applications. In contrast we later in the project installed ISDN cards in two Nubus-equipped Macintoshes. This process took in all less than an hour. The lesson to be learned from this is :

It is strongly advised that for ISDN cards, a clearly structured operating system with well-defined high-level communications functions and systems borders is used. Furthermore the card buses must be self-configuring. Emerging prospects for the PC compatibles is the plug-and-play initiative from Compaq, Intel, Microsoft and others (Uusitalo, 1994). There is also the PCI standard, Windows sockets and Microsoft telephony.

7. Practical results from the project

Skanska Software is to day using ISDN for communication and file sharing with a German firm. The networks are integrated over the Novell protocol and the connection is transparent. Experiences of Collaboration areas in the COOCOM project has contributed to Skanska Software starting up a BBS system for software updates for its customers.

The project has also resulted in a proposal for a continued collaboration in the area with design of the company knowledge node for communication support.

8. Future projects

8.1. IT-BASED MARKET-DRIVEN APPROACH

The emphasis here would be on the user's (market's) influence on design decisions. The project would suggest methods and processes for the tasks of selecting rooms, facades, functions, support systems. Important functions would be to visualize different design solutions to make them comprehensible for the layman and to analyze the needs of the user/market.

Methods for doing this would be:

- Walk-throughs through different models from a possibly world-wide data base of design solutions,
- An advanced user interface for the above mentioned database. This user interface may feature relevance feedback and relevance ranking, neural nets for classification of shapes (Reinhardt, 1994), case-based reasoning (Maiden, 1993) and other tools for retrieval of design solutions
- Analysis and structuring of user's needs through defining means and ends with e.g. Action-goal diagrams.
- Structured discussions to facilitate negotiations

8.2. DESIGN OF SUPPORT GROUPS

During the simulation, we used a number of people, facilitators, who helped analyzing and structuring the discussions. One future project would be to look at different roles for facilitators and computer tools to help communicate, visualize and structure arguments, visions and moot points during the early design stages and design decisions taken during e.g. a re-adaptation of a building's functions. This project would focus on enhancing the work between professional participants.

8.2.1 Focusing on collaboration over physical distances.

Furthermore, during physical meetings, support staff for the different participants could be available on-line. The support staff could include lawyers, technical experts, management and old people who have problems moving about. Soundly designed, such a system could significantly shorten the decision period since questions could be handled by domain experts on-line. E.g. an organization's law expert could approve agreements via screen sharing and video connection and sign an electronic document with a digital signature. For an example of digital signature tool see e.g. (Poole, 1994)



Figure 11 The conference is at the center with support staff on-line /Linus Christiansson, 1993/.

9. References

Aspects. The First Simultaneous Conference Software For The Macintosh. (1990). *Group Technologies*, Arlington Virginia USA. (328 pp).

Baecker, R., Nastos, D., Posner, I.R., & Mawby, K. L. (1993). "The user-centred iterative design of collaborative writing software". In S. Ashlund et al (ed.), *Proc. of the Conference on Human Factors in Computing Systems (INTERCHI'93)*, (pp. 399-405). Amsterdam

Bernstein B, *MacEuclid 1.1 b18*, (1993), University of Colorado at Boulder, from Sumex database at Stanford; also available on request from KBS-Media Lab

Christiansson P, (1992), "Dynamic Knowledge Nets in a changing building process". *Automation in Construction*, Vol 1 nb 4, March 1993, Elsevier Science Publishers B.V. (pp 307-322).

Christiansson P, Modin J, (1993), "Conceptual models for communicating knowledge in the building industry — implementation of the Cube system", *Management of Information Technology for Construction*, Singapore

Checkland P (1981), "Systems Thinking, Systems Practice", Chichester, Wiley.

COOCOM Etapp I. Samverkan i projektering och förvaltning med hjälp av informationsteknologi. 30 december, (1992). (5 sidor).

Eden C, Jones S, (1984) "Using repertory grids for problem construction", *Journal of Operational Research Society*, vol 35 n. 9 pp 779-790.

Halfhill T., (1994), "Image Retrieval for Compound Documents", *BYTE* 8/94 p. 104

Maiden N.A.M., (1993) "Case-based reasoning in complex design tasks".

Malm P. S., (1993)*The UnOfficial CSCW Yellow pages*, Univ. of Tromsø, from gorgon.tft.tele.no (192.135.199.112) as "pub/groupware/cscwyp.*"; also available on request from KBS-Media Lab

Microsoft Corp, Intel Corp, (1993), "Intel and Microsoft to Enable Integration of Personal Computers and Telephones", Press Release, Microsoft Corporation, Redmond, WA, May 4, Usenet newsgroup *comp.dcom.isdn*, Message-id: <1993May05.172551.18488@microsoft.com>; also available on request from KBS-Media Lab

Olson, G.M., McGuffin, L.S., Kuwana, E., & Olson, J.S., (1993) "Designing software for a group's needs: A functional analysis of synchronous groupware." In L. Bass & P. Dewan (Eds.), *User interface software* (pp. 129-148). New York: Wiley.

Olson, J.S., Olson, G.M., Storösten, M., & Carter, M., (1994) "Groupwork close up: A comparison of the group design process with and without a simple group editor." *ACM Transactions on Information Systems*, 11, 321-348.

Poole L., (1994), "System 7.5" *MacWorld* (US), pp.126-129

Price F, Yount R., (1993), "Hermes. Version 1.7. Macintosh Bulletin Board System. AOC Software Inc. (27 pp). (also from anonymous ftp from mac.archive.umich.edu)

Quarterman John, (1990), "The Matrix. Computer Networks and Conferencing Systems Worldwide". Digital Press. (719 pp).

Reinhardt A., (1994), "Managing the new Document" Cover Story, *BYTE* 8/94 pp 91-104

Rheingold, H (1991) "Virtual Reality" New York, Simon & Schuster.

Toulmin S., Rieke R., Janik A., (1984), *An Introduction to Reasoning*, second edition, New York

Uusitalo M., (1994) , "Plugga i och kör snart verklighet för PC-användare" *Svenska PC-world* issue 2 (In Swedish)